

# STEALTH<sup>®</sup> Pharmaceutical Metal Detector



## OVERVIEW:

Stealth Pharmaceutical metal detectors are custom manufactured to suit Pharmaceutical and/or Nutraceutical applications. Stealth detectors use digital signal processing technology and have high sensitivity levels to ensure the detection of the smallest ferrous, non-ferrous and stainless steel contaminants. The built-in data collection software with USB connectivity establishes the Stealth as an effective critical control point complying with stringent HACCP regulations.

## THE FORTRESS ADVANTAGE:

- **"Never Obsolete"** Commitment: detectors are always supported with parts and services
- Standard electronics configuration across product line allowing easy support and trouble shooting
- Modular design; have fewer components
- Custom built detectors or stock sizes
- **Simple Operation, Outstanding Reliability, Exceptional Performance**

## KEY FEATURES:

- Contact Reporter Software Included
- Digital Signal Processing Technology
- Ultra Sensitive Detection
- AutoTest: Self Diagnostic Testing
- Easy "Fast" Calibration
- Automatic Configuration for Iron-Enriched
- System Set-Up in Seconds
- Flash Memory Stability
- Multi-Level Password Protection
- Detailed USB Data Collection
- FDA Compliant
- Compatible with High Speed lines
- Adjustable Height and Tilt
- Validation Package Included

## APPLICATIONS:

- Tablets
- Pharmaceuticals
- Capsules
- Bubble Gum Tablets
- Nutraceuticals
- Extruded Candy

*Don't See Your Application? Please Contact Us!*

## AVAILABLE OPTIONS:

Contact Communication Software



Fortress Technology Inc.  
51 Grand Marshall Dr,  
Toronto, ON, M1B 5N6  
Canada  
Tel: 1-888-220-8737  
sales@fortresstechnology.com

Fortress Technology (Europe) Ltd.  
The Phantom Building  
7 Beaumont Road, Banbury,  
OX16 1RH UK  
Tel: +44 (0) 1295 256 266  
sales-UK@fortresstechnology.com

Fortress Technology Sistemas de Inspeção Ltda.  
ROD. Presidente Tancredo de Almeida Neves  
3007 - Km 30,5 - Vila Rosina  
Caieiras - São Paulo, CEP: 07748-400  
Fone: 55-11-3641-6153  
vendas@fortress-iis.com.br

**FORTRESS<sup>®</sup>**  
TECHNOLOGY

www.FortressTechnology.com

# STEALTH<sup>®</sup> Pharmaceutical Metal Detector

Powerful Digital Signal Processing (DSP) Technology

Multi-Level Password Protection

Product Library Stores Multiple Product Settings for Easy Recall

User-Friendly Multi-Language Control Panel Interface

Adjustable Head Tilt Angle

Powered Height Adjustment (8" / 20cm)

Modular Design for Increased Reliability

No Tools Required to Remove Parts for Cleaning

Custom Aperture Sizes

Automatic QA Testing and Calibration

Custom Configuration for Iron-Enriched Products

Dual Power with Auto-balance and Ultra-sensitivity levels

USB Port for access to QA Reports, Configuration and Firmware Updates

FDA Approved Product Contact Parts

Side Divert Reject System

Reject Catcher Available

Lockable Swivel Casters for Portability

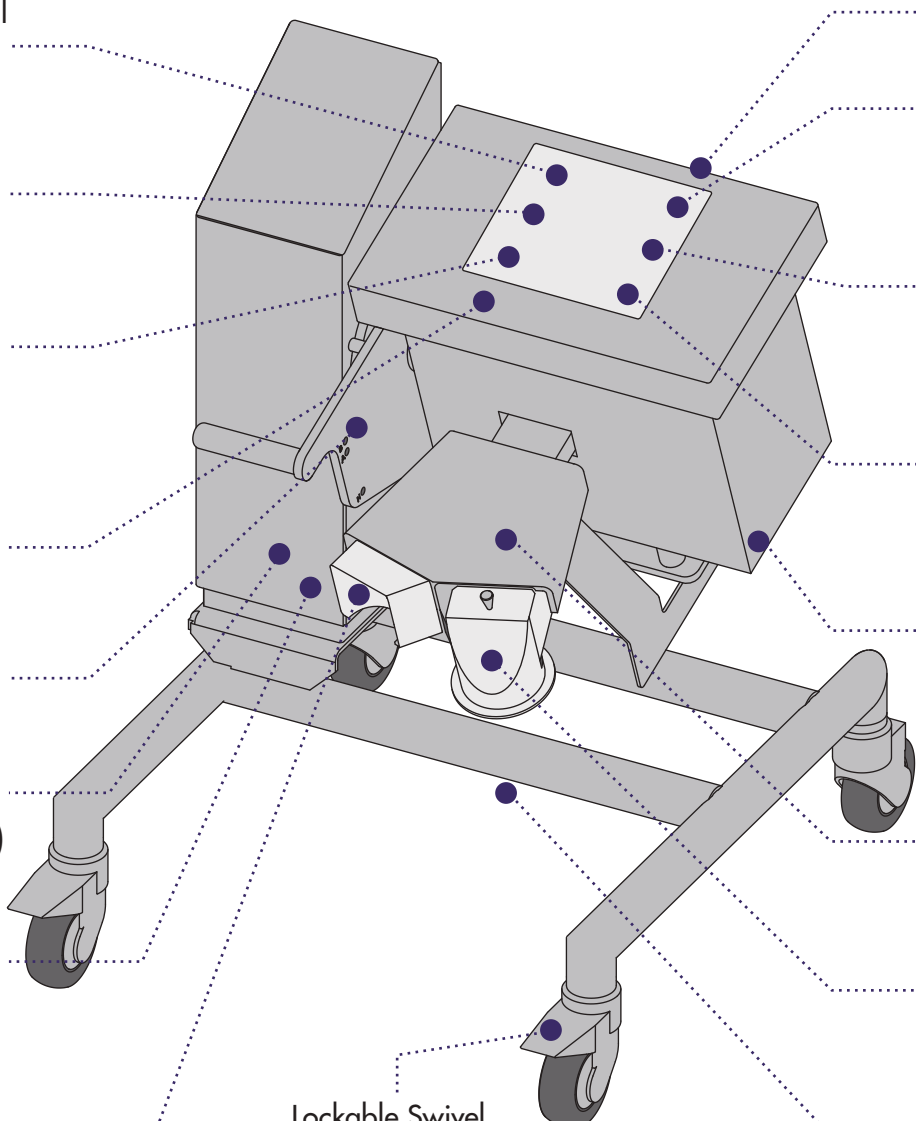

## DETECTOR OPTIONS & SPECIFICATIONS:

Sensitivity	0.15mm Ferrous and Non-Ferrous, 0.3mm Stainless Steel (300 series)
Throughput	Up to 30,000 tablets per minute
Construction	316 Stainless Steel
Extra-Rugged Casing	Vibration immunity and stability in heavy duty applications and harsh environments
Rating	Nema 4X / IP69K
Network Communications	RS485, Ethernet / Wireless via Contact Communications Software
Electrical	100-240v Single phase, 1 amp, 50-60Hz

Simple Operation. Outstanding Reliability. Exceptional Performance.



Copyright © 2018 Fortress Technology Inc. All rights reserved. Patent Pending. The information, designs and artwork contained in this document are confidential and may not be disseminated, distributed or copied without written consent from Fortress Technology Inc. Specifications, designs, features and technology subject to change without notice.